

DELI

ABSOLUTELY DELICIOUS.



THE SIGN OF COOL QUALITY

DELI

DELICIOUS SOLUTION FOR DEMANDING PRODUCTS

New innovative design from Norpe. The first semi-vertical plug-in multideck for multiplexing. Deli offers absolutely delicious product display for delicacies but also for large volumes of fast moving products.



DELI-135-120

OPERATIONAL RELIABILITY AND INHERENT ENERGY SAVING

- Superior temperature performance
- Hot gas evaporation and optional LED lighting and night blinds save up to 40 % in comparison to other impulse cabinets (+25°C, Rh 60 %).
- Glass end panels allow excellent product visibility and wide branding possibilities
- Deli can be multiplexed into longer runs and built back to back to form shopping islands
- Deli is user friendly; it is easy to move on castors.
- Pull-out condenser unit is designed for easy cleaning and service





DELI-135-90



Deli-135-60



Deli-186 with lockable shutter.

THE MANY FACES OF DELI. - ALL BEAUTIFUL.

Deli builds an impressive display with easy access to the customer. Deli can be easily used for marketing, promoting sales campaigns and brands.

You can choose what Deli will sell - and where. It will look delicious.

Sandwiches

Beverages

Salads

Dairy products

Cold cuttings

Pies

Ready meals

Convenience stores

Caféterias

Petrol forecourts

Food retail

Kiosks

Restaurants

MULTIPURPOSE DELI



Deli-135 shoparound with ambient shelving.



Deli-135 multiplexed.

ECOLOGY



CARING FOR THE FUTURE

- Norpe is fully certified under ISO 14001:2004
- Night blinds
- Hot gas defrost water evaporation
- LED lights
- Durable steel construction
- HFC-free polyurethane as insulation
- 99% of cabinet parts are recyclable
- Low energy fans
- Norpe dual evaporator reduces the frequency and time required for defrosting



Deli has all elements of efficiency! This cabinet is controlled by the NRC-100 electronic control device. Hot gas defrost water evaporation and optional LED-lighting and night blind ensure energy saving up to 40 % in comparison to other impulse cabinets.

NRC-100 CONTROL DEVICE

- Possibility to adjust the temperature of the cabinet to suit different product groups
- Even temperature improves the product shelf life
- Built-in condenser overheat protection
- Display of error messages



Deli-135 with LED-lighting.



Deli-135 with nightblind.





DELI-135 shoparound island



Deli-135-90



Deli-135 with shelves for PET bottles and plastic end panels.

DELI EQUIPPED TO SUITE YOUR PURPOSES

STANDARD EQUIPMENT

- Castors - easy to move
- Lighting in the canopy
- Integral condensing unit complete with controller (refrigerant R404A)
- Electronic thermostat
- Hot gas defrost water disposal
- Acrylic front riser for base

OPTIONAL ACCESSORIES

- Roller blind
- Adjustable feet
- Ticket rail for shelf
- Acrylic front riser for shelf
- Low energy fans
- Plastic end panels
- LED lighting under shelves
- Shelves for improved display of PET bottles (Deli-135)
- Glass shelves for luxury product display (Deli-135)
- Ambient shelving to form an attractive shop-around island.
- Mounting kit for back-to-back
- Lockable night cover



DELI - 135

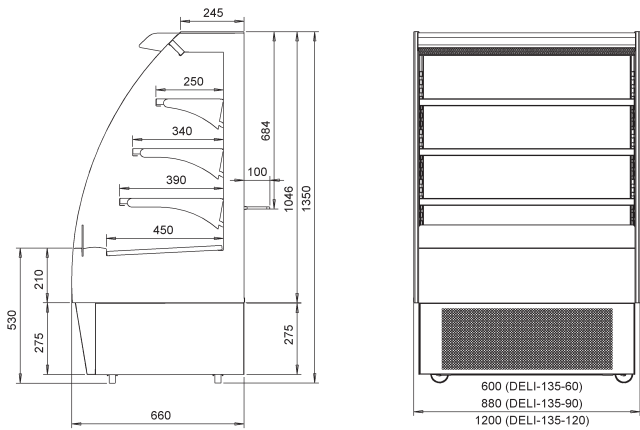

DELI-135 BACK TO BACK WITH AMBIENT SHELVING

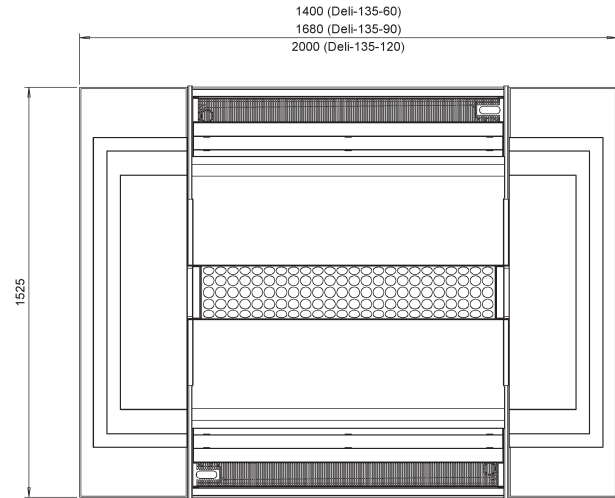

DELI - 186

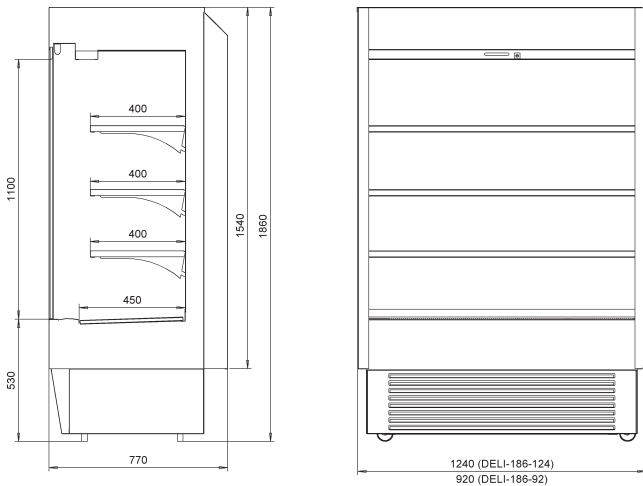

DELI-186

AMBIENT SHELVING FOR DELI-135

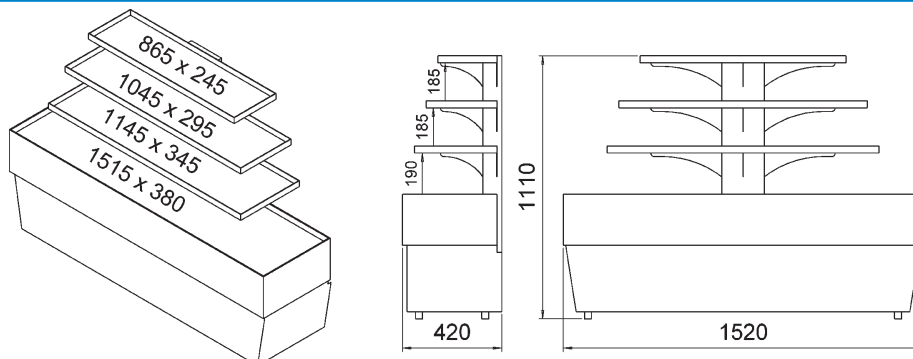
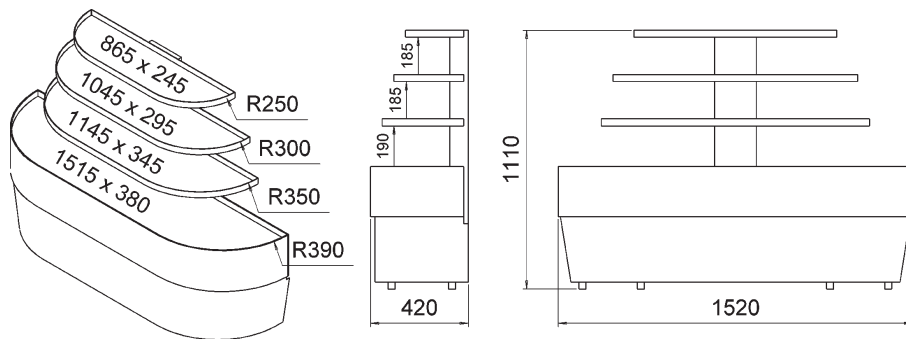

TECHNICAL SPECIFICATIONS

MODEL	HEIGHT, MM	LENGTH, MM	DEPTH, MM	REFR. AREA, M ²	POWER INPUT, W	POWER CONSUMPTION kWh/24 H (WITH NIGHT CURTAIN)	PET BOTTLE CAPACITY (PCS/ 500 ML)	GROSS WEIGHT, KG
DELI-135-60-M-HE	1350	600	660	0.8	539	9.6	104	135
DELI-135-90-M-HE	1350	880	660	1.2	792	14.2	168	162
DELI-135-120-M-HE	1350	1200	660	1.7	1031	18.5	222	200
DELI-186-92-M-HE	1860	920	770	1.4	792	14.2	-	238
DELI-186-124-M-HE	1860	1240	770	1.9	1069	19.5	-	286

The technical specifications relate to the following ambient conditions. Ambient temperature +25 °C, relative humidity 60 %. Electrical supply 230 V, 1 phase, 50 cycles.

HOW WOULD YOU LIKE YOUR DELI?

Our standard colours are white and white aluminum. If you would like the cabinet colour to match and support your brand or concept even better, please contact your local Norpe partner. The colours in the picture are suggestive.



TECHNICAL DATA

CONSTRUCTION

- Supporting construction and exterior made of galvanised steel sheet
- Deli-135 (height 1350 mm) available in three different lengths; 600, 880 and 1200 mm
- Deli-186 brushed stainless steel with lockable shutter . Available in two lengths 920 and 1240 mm
- Glass end panels ensure excellent product visibility from the side
- 99 % of cabinet parts recyclable
- Intended for indoor use only





Norpe Ltd. Tel. +358 19 537 8000
www.norpe.fi • www.norpe.com • marketing@norpe.fi

FINLAND Norpe Suomi Oy Tel. +358 19 537 8000
www.norpe.fi • www.norpe.com • marketing@norpe.fi

SWEDEN Norpe AB Tel. +46 8 594 112 00
www.norpe.se • info@norpe.se

NORWAY Norpe AS Tel. +47 33 36 35 00
www.norpe.no • post@norpe.no

POLAND Norpe Polska Sp. zo o. Tel. +48 22 882 00 20
www.norpe.pl • norpe@norpe.pl

RUSSIA Norpe Russia Tel. +7 812 273 3912
www.norpe.com.ru • sale@norpe.spb.ru

ESTONIA Norpe Eesti Oü Tel. +372 656 1717
www.norpe.ee • info@norpe.ee

LATVIA Norpe Latvia Filiale Tel. +371 736 9827
www.norpe.com • info@norpe.lv

