

GUSTO SO

A PART OF DYNAMIC VISION COLLECTION

Gusto displays your products in the best possible way. In Gusto you get large display area together with functionality and ergonomic design. Now it can be multiplexed elegantly with Inspi.



THE SIGN OF COOL QUALITY

Caring for the future

Flexible Gusto

Gusto's light design highlights your products. It is especially ideal for displaying meat, fish, cold cuts, cheese and semi finished products.

GUSTO STANDARD FEATURES

- External surface of galvanised steel sheet
- High quality stove enamelling
- Stainless steel option also available
- Adjustable legs and plinths with washers
- Uniform stainless steel evaporator cover
- Drain outlet pipe with a strainer
- Work surface of stainless steel
- Insulation of HCFC free polyurethane foam

MODEL VARIANTS

- Display elements 125, 188, 250, 375 cm
- Internal angle 45° IA, external angle 45° EA
- Condensing unit M / Condensing unit O
- Multiplexing model
- Service model / Self-Service model
- Multirama MR
- Non-refrigerated under-storage AS
- Refrigerated under-storage CS
- Uncovered lower part P
- Gravity cooling GC
- Forced-air cooling FA
- Four different display case options



SERVICE DISPLAY

REFRIGERATION

- The condensing unit is located in the machinery compartment on the left hand end of the display as seen from the customer's side
- Refrigerant R404A
- Cabinets for remote installation come with an expansion valve
- In all models the evaporator is located under the worktop, on the back wall in the upper part of the cabinet
- Refrigeration is provided by gravity or forced-air cooling
- Refrigerated under-storage is (CS)

STANDARD EQUIPMENT

- Evaporator
- Upper lighting (service)
- Control panel (corners 1 pc / 45°, 90°)
- Fan-system for the front glass
- Plate end panel 35 mm

CABINETS WITH INTEGRAL CONDENSING UNIT

- Complete condensing unit with R404A refrigerant
- Electronic thermostat (including control and defrost cut-out thermostats, defrost timer and temperature display)
- Defrost water tray

CABINETS FOR REMOTE INSTALLATION

- Expansion valve for refrigerant R404A
- Defrost cut-out thermostat in the understorage of CS models
- Defrost water outlet pipe of the cabinet length
- Thermometers

CHOICE OF FRONT GLASS

SERVICE

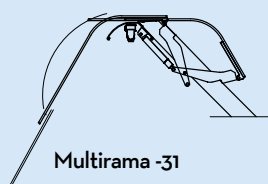
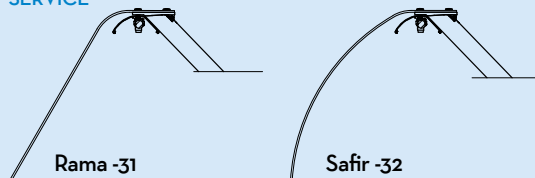

SELF SERVICE

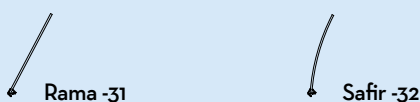

GUSTO SO

TECHNICAL DATA

Front height	580 mm
Depth	1160 mm
Height	880, 1180 mm
Length	1250, 1875, 2500, 3750 mm
Air Temperature	0...+2 °C

	MIN. POWER INPUT W	MAX. POWER INPUT W	REFR. AREA M ²
SO58-116-118-125-S-GC-WS-o	50	500	1.03
SO58-116-118-188-S-GC-WS-o	70	720	1.54
SO58-116-118-250-S-GC-WS-o	100	950	2.05
SO58-116-118-375-S-GC-WS-o	140	1390	3.08
SO58-116-118-188-S-GC-CS-o	290	950	1.54
SO58-116-118-GC-CS-250-o	430	1290	2.05
SO58-116-118-GC-CS-375-o	650	1900	3.08
SO58-116-118-FA-WS-125-o	50	500	1.03
SO58-116-118-FA-WS-188-o	90	740	1.54
SO58-116-118-FA-WS-250-o	140	990	2.05
SO58-116-118-FA-WS-375-o	180	1430	3.08
SO58-116-118-FA-CS-188-o	310	970	1.54
SO58-116-118-FA-CS-250-o	470	1330	2.05
SO58-116-118-FA-CS-375-o	670	1940	3.08
SO58-116-88-GC-WS-125-o	10	460	1.03
SO58-116-88-GC-WS-188-o	20	670	1.54
SO58-116-88-GC-WS-250-o	20	870	2.05
SO58-116-88-GC-WS-375-o	30	1280	3.08
SO58-116-88-GC-CS-188-o	240	900	1.54
SO58-116-88-GC-CS-250-o	350	1210	2.05
SO58-116-88-GC-CS-375-o	525	1800	3.08
SO58-116-88-FA-WS-125-o	20	500	1.03
SO58-116-88-FA-WS-188-o	40	690	1.54
SO58-116-88-FA-WS-250-o	60	910	2.05
SO58-116-88-FA-WS-375-o	70	1300	3.08
SO58-116-88-FA-CS-188-o	260	910	1.54
SO58-116-88-FA-CS-250-o	390	1250	2.05
SO58-116-88-FA-CS-375-o	560	1830	3.08
SO58-116-118-IA-WS-o	40	430	0.81
SO58-116-118-EA-WS-o	40	370	0.87
SO58-116-88-IA-WS-o	10	370	0.81
SO58-116-88-EA-WS-o	10	320	0.87
SO58-116-118-125-F-o	930	930	
SO58-116-118-188-F-o	985	985	



OPTIONAL ACCESSORIES

- Expansion valves for other refrigerants
- Plate end panel 35 mm
- Stainless steel plinths
- Three material choices; painted plate, stainless steel and wood
- Intermediate shelf with lighting (service)
- Lower front lighting (not possible with wood decoration)
- Stainless steel display grid, 1-, 2- or 3-step
- Stainless steel display plate, 1-, 2- or 3-step
- Stainless steel frame for bowls, 2- or 3-step
- Stainless steel bowl 265x165x65
- Stainless steel bowl 325x265x65
- Stainless steel bowl 325x530x65
- Stainless steel ice flake grids
- Wooden grill
- Stainless steel stand for scales and slicers 450x400 and 550x500
- Chopping board 270x350 and 450x450
- Paper bag holder (for straight display elements), length 580 mm
- Stainless steel basket rail (not for wood decorated cabinets)
- Stainless steel bowl 150 mm for CS model
- Castors fitted to display elements of 125, 188 and 250 cm in length
- Sockets (for straight display elements)
- Defrost heater for the upper part of the cabinet

VISION COLLECTION

How to read the code:

SO58-116-88-250*

Front height Depth Height Length

Measures are centimeters.

- * IA Internal angle
EA External angle
GC Gravity cooling
AS Ambient storage
CS Cold storage
FA Fan assisted

GUSTO SO



EA-45

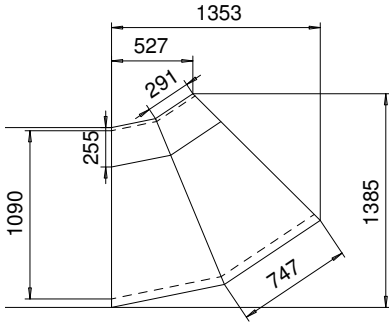

EA-90

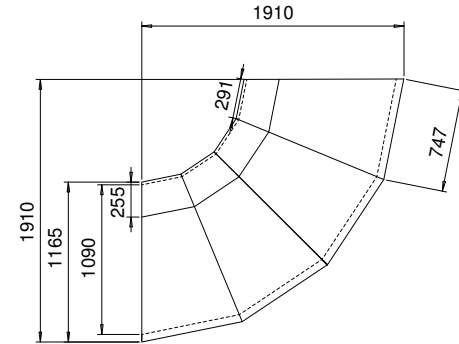

SO58-116-118 GUSTO

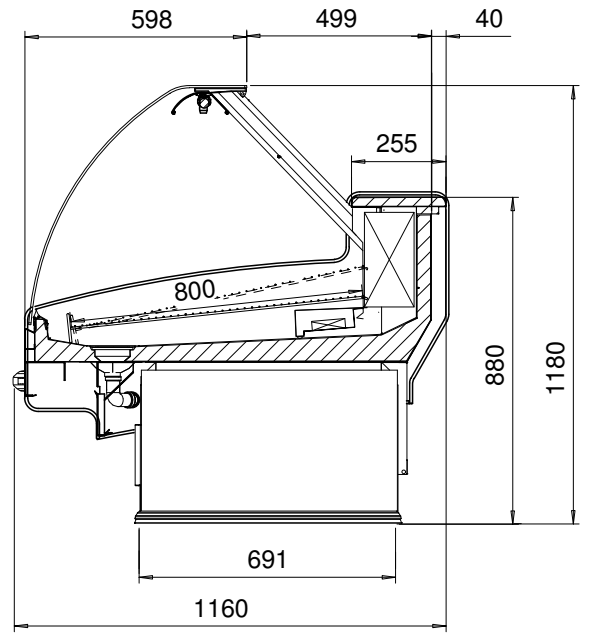

IA-45

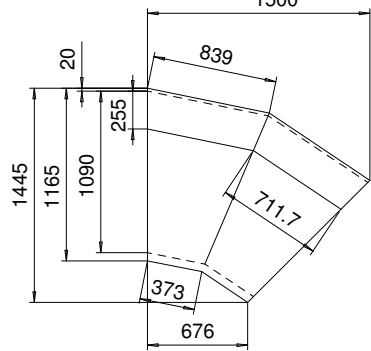

IA-90

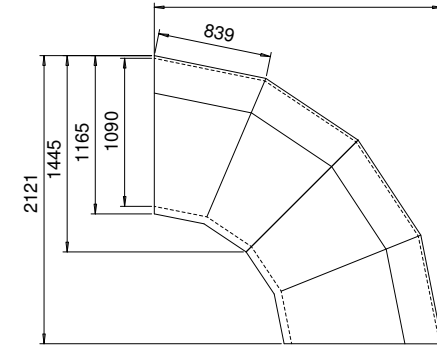

SO58-116-88 GUSTO

